



Structural Performance Certification Authorization Report

Pocahontas Aluminum Company, Inc.

PO Box 756, 2001 Industrial Drive
Pocahontas, AR 72455, USA

Certification ID:	757-113
Company Code:	757
Certification Date:	8/20/2015
Revision No:	1
Revision Date:	5/17/2022
Expiration Date:	6/4/2025

Product Rating Information:

Model:	PEL21W PVC Fixed			
Operator Type:	FW			
Configuration:	No			
Referenced Standard:	AAMA/WDMA/CSA 101/I.S.2/A440-08/11			
Product Rating:	Class R-PG50 1219x1854 (48x73)-Type FW			
Rated Dimensions:	Max Width:	48 in	Max Height:	73 in

Qualifying Test information:

Test Report No:	ATI-E9101.02-501-47
Test Report Expiration:	6/4/2025

This Certification Authorization Report (CAR) is issued by Keystone Certifications, Inc. (KCI) after full validation review, and is based on a standardized evaluation of the product conducted by an independent accredited laboratory in accordance with the specified referenced standard. Actual fenestration product performance may vary based on many factors, including installation, condition of the wall/roof substrate and the age of the product and installation components.

This report indicates the product is eligible for the application of Keystone Certification Program certification labels. Licensee stipulates in affixing certification labels to products, that those products are representative of the specimen evaluated and documented for certification authorization. Only products bearing such a certification label shall be considered certified. The information in this report can be verified at www.keystonecerts.com

Authorized By:

Shaun Shaull Shaun Shaull
2022.05.17 16:06:09 -04'00'

Keystone Certifications, Inc.
145 Limekiln Rd, Suite 100B
New Cumberland, PA 17070
Phone: 717-932-8500



Structural Performance Certification Authorization Report

Revision History

Rev #	Date	Description
0	8/20/2015	Initial Issuance
1	5/17/2022	Granted 3 Year Extension



Structural Performance Certification Authorization Report

Pocahontas Aluminum Company, Inc.

PO Box 756, 2001 Industrial Drive
Pocahontas, AR 72455, USA

Certification ID:	757-114
Company Code:	757
Certification Date:	8/20/2015
Revision No:	1
Revision Date:	5/17/2022
Expiration Date:	6/4/2025

Product Rating Information:

Model:	PEL21W PVC Fixed			
Operator Type:	FW			
Configuration:	No			
Referenced Standard:	AAMA/WDMA/CSA 101/I.S.2/A440-08/11			
Product Rating:	Class R-PG50 914x1549* (36x61*)-Type FW			
Rated Dimensions:	Max Width:	36 in	Max Height:	61 in

Qualifying Test information:

Test Report No:	ATI-E9101.02-501-47
Test Report Expiration:	6/4/2025

This Certification Authorization Report (CAR) is issued by Keystone Certifications, Inc. (KCI) after full validation review, and is based on a standardized evaluation of the product conducted by an independent accredited laboratory in accordance with the specified referenced standard. Actual fenestration product performance may vary based on many factors, including installation, condition of the wall/roof substrate and the age of the product and installation components.

This report indicates the product is eligible for the application of Keystone Certification Program certification labels. Licensee stipulates in affixing certification labels to products, that those products are representative of the specimen evaluated and documented for certification authorization. Only products bearing such a certification label shall be considered certified. The information in this report can be verified at www.keystonecerts.com

Authorized By:

Shaun Shaul
 Shaun Shaul
 2022.05.17 16:07:42
 -04'00'

Keystone Certifications, Inc.
 145 Limekiln Rd, Suite 100B
 New Cumberland, PA 17070
 Phone: 717-932-8500



Structural Performance Certification Authorization Report

Revision History

Rev #	Date	Description
0	8/20/2015	Initial Issuance
1	5/17/2022	Granted 3 Year Extension

**INSTALLATION METHOD
PVC (VINYL) PI21 FIXED PICTURE WINDOW
ELEVATION & ANCHOR LAYOUT**

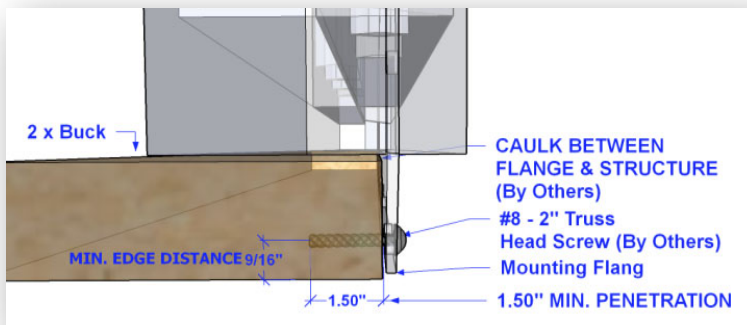
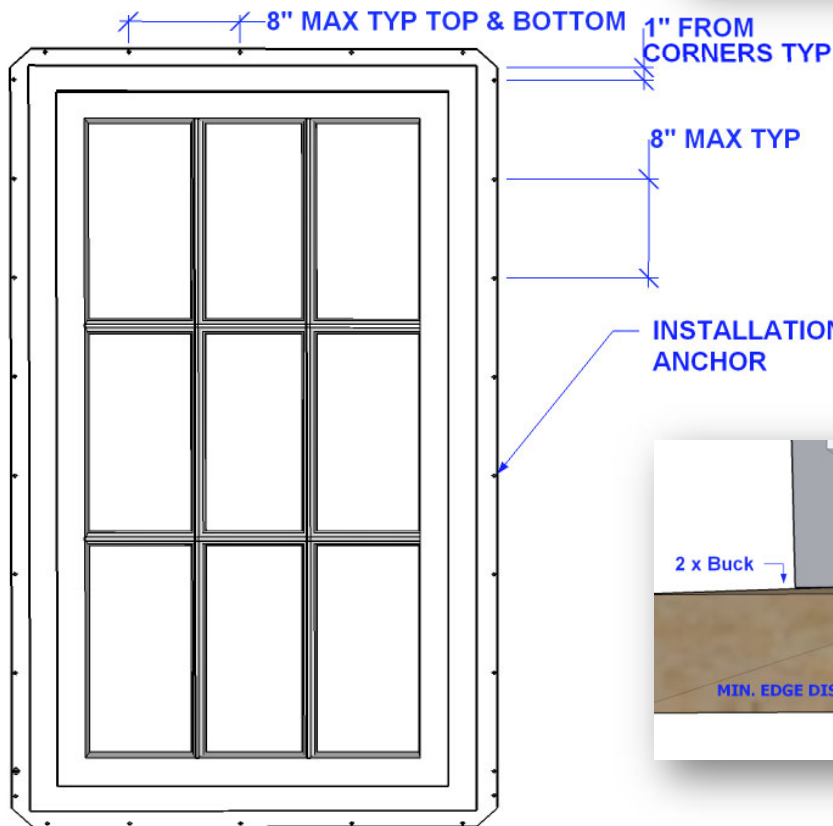
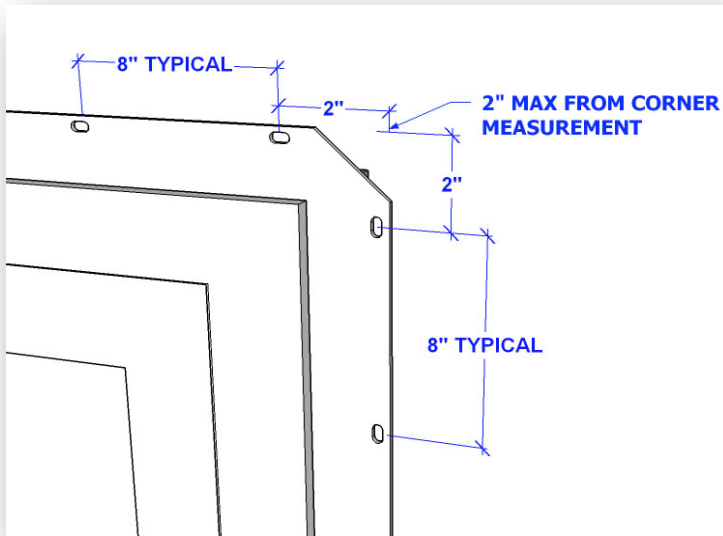
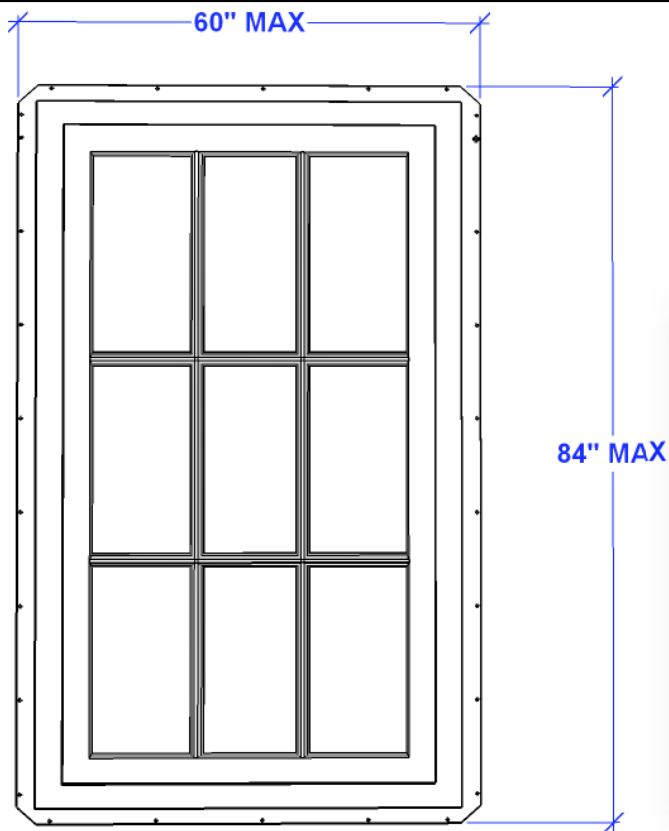

1" FROM CORNERS TYP
TOP & BOTTOM

SCALE: NTS

DWN BY: AMM

CHK BY: KEA

DATE: 10/13/15

TITLE:
INSTALLATION METHOD
PVC (VINYL) PI21 FIXED PICTURE WINDOW
ELEVATION & ANCHOR LAYOUT

PREPARED BY:
POCAHONTAS ALUMINUM COMPANY, INC.
2001 INDUSTRIAL DRIVE
POCAHONTAS, AR 72455
PH: 870-892-3689 FAX: 870-892-9858

REVISIONS

NO.	DESCRIPTION	BY	DATE

COPYING OR
DUPLICATION IS
PROHIBITED WITHOUT
WRITTEN PERMISSION
FROM POCAHONTAS
ALUMINUM
COMPANY, INC.





TEST REPORT

Report No.: E9101.02-501-47

Rendered to:

POCAHONTAS ALUMINUM CO., INC.
Pocahontas, Arizona

PRODUCT TYPE: PVC Fixed Window
SERIES/MODEL: PEL21W

SPECIFICATION(S): AAMA/WDMA/CSA 101/I.S.2/A440-11, *NAFS 2011 - North American Fenestration Standard/Specification for Windows, Doors, and Skylights*

AAMA/WDMA/CSA 101/I.S.2/A440-08, *NAFS - North American Fenestration Standard/Specification for Windows, Doors, and Skylights*

Title	Summary of Results	
	Test Specimen #1	Test Specimen #2
AAMA/WDMA/CSA 101/I.S.2/A440-08 and -11	Class R-PG50 1219 x 1854 (48 x 73) - Type FW	Class R-PG50 914 x 1549* (36 x 61*) - Type FW
Design Pressure	±2400 Pa (±50.13 psf)	±2400 Pa (±50.13 psf)
Air Infiltration	0.1 L/s/m ² (0.01 cfm/ft ²)	0.1 L/s/m ² (0.01 cfm/ft ²)
Canadian Air Infiltration/Exfiltration Level	Fixed	Fixed
Water Penetration Resistance Test Pressure	360 Pa (7.52 psf)	360 Pa (7.52 psf)

Test Completion Date: 06/04/15

Reference must be made to Report No. E9101.02-501-47, dated 07/31/15 for complete test specimen description and detailed test results.



1.0 Report Issued To: Pocahontas Aluminum Co., Inc.
2001 Industrial Drive
Pocahontas, Arizona 72455

2.0 Test Laboratory: Architectural Testing, Inc., a subsidiary of Intertek (Intertek-ATI)
1140 Lincoln Avenue
Springdale, Pennsylvania 15144
724-275-7100

3.0 Project Summary:

3.1 Product Type: PVC Fixed Window

3.2 Series/Model: PEL21W

3.3 Compliance Statement: Results obtained are tested values and were secured by using the designated test method(s). The specimens tested successfully met the performance requirements for the following ratings:

Test Specimen(s)	Title	Summary of Results
1	101/I.S.2/A440-08 and -11	Class R-PG50 1219 x 1854 (48 x 73) - Type FW
2	101/I.S.2/A440-08 and -11	Class R-PG50 914 x 1549* (36 x 61*) - Type FW

General Note: An asterisk (*) next to the size designation indicates that the size tested for optional performance was smaller than the Gateway test size for the product type and class.

3.4 Test Dates: 06/22/15 - 06/24/15

3.5 Test Record Retention End Date: All test records for this report will be retained until June 24, 2019.

3.6 Test Location: Veka Inc. test facility in Fombell, Pennsylvania. Calibration of test equipment was performed by Intertek-ATI in accordance with AAMA 205-01 "In-Plant Testing Guidelines for Manufacturers and Independent Laboratories".

3.7 Test Specimen Source: The test specimen(s) were provided by the client. Representative samples of the test specimen(s) will be retained by Intertek-ATI for a minimum of four years from the test completion date.

3.8 Drawing Reference: The test specimen drawings have been reviewed by Intertek-ATI and are representative of the test specimen(s) reported herein. Test specimen construction was verified by Intertek-ATI per the drawings located in Appendix C. Any deviations are documented herein or on the drawings.

3.0 Project Summary: (Continued)

3.9 List of Official Observers:

<u>Name</u>	<u>Company</u>
Doug Merry	Veka Inc.
Cornell Charles	Veka Inc.
Joseph Allison	Intertek-ATI

4.0 Test Specification(s):

AAMA/WDMA/CSA 101/I.S.2/A440-11, *NAFS 2011 - North American Fenestration Standard/Specification for Windows, Doors, and Skylights*

AAMA/WDMA/CSA 101/I.S.2/A440-08, *NAFS - North American Fenestration Standard/Specification for Windows, Doors, and Skylights*

5.0 Test Specimen Description:

5.1 Product Sizes:

Test Specimen #1:

Overall Area: 2.3 m ² (24.3 ft ²)	Width		Height	
	millimeters	inches	millimeters	inches
Overall size	1219	48	1854	73

Test Specimen #2:

Overall Area: 1.4 m ² (15.3 ft ²)	Width		Height	
	millimeters	inches	millimeters	inches
Overall size	914	36	1549	61

The following descriptions apply to all specimens.

5.2 Frame Construction:

Frame Member	Material	Description
Head, sill, jambs	PVC	Extruded

	Joinery Type	Detail
All corners	Mitered	Thermally welded

5.3 Weatherstripping: No weatherstripping was utilized.

5.0 Test Specimen Description: (Continued)

5.4 Glazing: *No conclusions of any kind regarding the adequacy or inadequacy of the glass in any glazed test specimen(s) can be made.*

Test Specimen #1:

Glass Type	Spacer Type	Interior Lite	Exterior Lite	Glazing Method
5/8" IG	Rectangular-shaped steel, single sealed	1/8" annealed	1/8" annealed	The glass was set from the exterior against a silicone sealant and secured with rigid PVC glazing beads

Test Specimen #2:

Glass Type	Spacer Type	Interior Lite	Exterior Lite	Glazing Method
5/8" IG	Rectangular-shaped steel, single sealed	3/32" annealed	3/32" annealed	The glass was set from the exterior against a silicone sealant and secured with rigid PVC glazing beads

Location	Quantity	Daylight Opening		Glass Bite
		millimeters	inches	
Specimen #1 frame	1	1153 x 1788	45-3/8 x 70-3/8	5/8"
Specimen #2 frame	1	848 x 1483	33-3/8 x 58-3/8	5/8"

5.5 Drainage: No drainage was utilized

5.6 Hardware: No hardware was utilized.

5.7 Reinforcement: No reinforcement was utilized.

6.0 Installation:

The specimen was installed into a Spruce-Pine-Fir wood buck. The rough opening allowed for a 1/8" shim space. The nail fin perimeter of the window was sealed with a silicone sealant.

Location	Anchor Description	Anchor Location
Integral nail fin	#8 x 2" truss head screw	Nominally spaced at 4-1/2" on center

7.0 Test Results: The temperature during testing was 21°C (70°F). The results are tabulated as follows:

Test Specimen #1:

Title of Test	Results	Allowed	Note
Air Leakage, Infiltration per ASTM E 283 at 75 Pa (1.57 psf)	0.1 L/s/m ² (0.01 cfm/ft ²)	1.5 L/s/m ² (0.3 cfm/ft ²) max.	1
Air Leakage, Exfiltration per ASTM E 283 at 75 Pa (1.57 psf)	0.1 L/s/m ² (0.01 cfm/ft ²)	1.5 L/s/m ² (0.3 cfm/ft ²) max.	1
Canadian Air Infiltration/Exfiltration Level	Fixed	N/A	
Water Penetration, per ASTM E 547	N/A	N/A	3
Uniform Load Deflection, per ASTM E 330	N/A	N/A	3
Uniform Load Structural, per ASTM E 330	N/A	N/A	3
Forced Entry Resistance, per ASTM F 588, Type: D - Grade: 40	Pass	No entry	
Thermoplastic Corner Weld	Pass	Meets as stated	
Optional Performance			
Water Penetration, per ASTM E 547 at 360 Pa (7.52 psf)	Pass	No leakage	2
Uniform Load Deflection, per ASTM E 330 taken at the right jamb +2400 Pa (+50.13 psf) -2400 Pa (-50.13 psf)	2.5 mm (0.10") 10.3 mm (0.40")	Report Only	4, 5, 6
Uniform Load Structural, per ASTM E 330 taken at the right jamb +3600 Pa (+75.19 psf) -3600 Pa (-75.19 psf)	0.5 mm (0.02") 0.5 mm (0.02")	0.5 mm (0.02") max. 0.5 mm (0.02") max.	5, 6

7.0 Test Results: (Continued)

Test Specimen #2:

Title of Test	Results	Allowed	Note
Air Leakage, Infiltration per ASTM E 283 at 75 Pa (1.57 psf)	0.1 L/s/m ² (0.01 cfm/ft ²)	1.5 L/s/m ² (0.3 cfm/ft ²) max.	1
Air Leakage, Exfiltration per ASTM E 283 at 75 Pa (1.57 psf)	0.1 L/s/m ² (0.01 cfm/ft ²)	1.5 L/s/m ² (0.3 cfm/ft ²) max.	1
Canadian Air Infiltration/Exfiltration Level	Fixed	N/A	
Water Penetration, per ASTM E 547	N/A	N/A	3
Uniform Load Deflection, per ASTM E 330	N/A	N/A	3
Uniform Load Structural, per ASTM E 330	N/A	N/A	3
Forced Entry Resistance, per ASTM F 588, Type: D - Grade: 40	Pass	No entry	
Thermoplastic Corner Weld	Pass	Meets as stated	
Optional Performance			
Water Penetration, per ASTM E 547 at 360 Pa (7.52 psf)	Pass	No leakage	2
Uniform Load Deflection, per ASTM E 330 taken at the right jamb +2400 Pa (+50.13 psf) -2400 Pa (-50.13 psf)	2.0 mm (0.08") 4.5 mm (0.18")	Report Only	4, 5, 6
Uniform Load Structural, per ASTM E 330 taken at the right jamb +3600 Pa (+75.19 psf) -3600 Pa (-75.19 psf)	0.3 mm (0.01") 0.3 mm (0.01")	0.5 mm (0.02") max. 0.5 mm (0.02") max.	5, 6

7.0 Test Results: (Continued)

Note 1: The tested specimen meets (or exceeds) the performance levels specified in AAMA/WDMA/CSA 101/I.S.2/A440 for air leakage resistance.

Note 2: Without insect screen.

Note 3: The client opted to start at a pressure higher than the minimum required. Test results are reported under Optional Performance.

Note 4: The deflections reported are not limited by AAMA/WDMA/CSA 101/I.S.2/A440 for this product designation. The deflection data is recorded in this report for special code compliance and information only.

Note 5: Loads were held for 10 seconds.

Note 6: Tape and film were not used to seal against air leakage during structural testing.



Intertek-ATI will service this report for the entire test record retention period. Test records such as detailed drawings, datasheets, representative samples of test specimens, or other pertinent project documentation, will be retained by Intertek-ATI for the entire test record retention period.

This report does not constitute certification of this product nor an opinion or endorsement by this laboratory. It is the exclusive property of the client so named herein and relates only to the specimen(s) tested. This report may not be reproduced, except in full, without the written approval of Intertek-ATI.

For INTERTEK-ATI

Joseph E. Allison
Senior Technician

Lynn George
Director – Regional Operations

JEA:sld

Attachments (pages): This report is complete only when all attachments listed are included.

Appendix-A: Alteration Addendum (1)

Appendix-B: Location of Air Seal (1)

Appendix-C: Drawings (1) Complete drawings packet on file with Intertek-ATI



Appendix A

Alteration Addendum

Note: No alterations were required.

Appendix B

Location of Air Seal: The air seal between the test specimen and the test wall is detailed below. The seal is made of foam weatherstripping and is attached to the edge of the test specimen buck. The test specimen buck is placed against the test wall and clamped in place, compressing the weatherstripping and creating a seal.

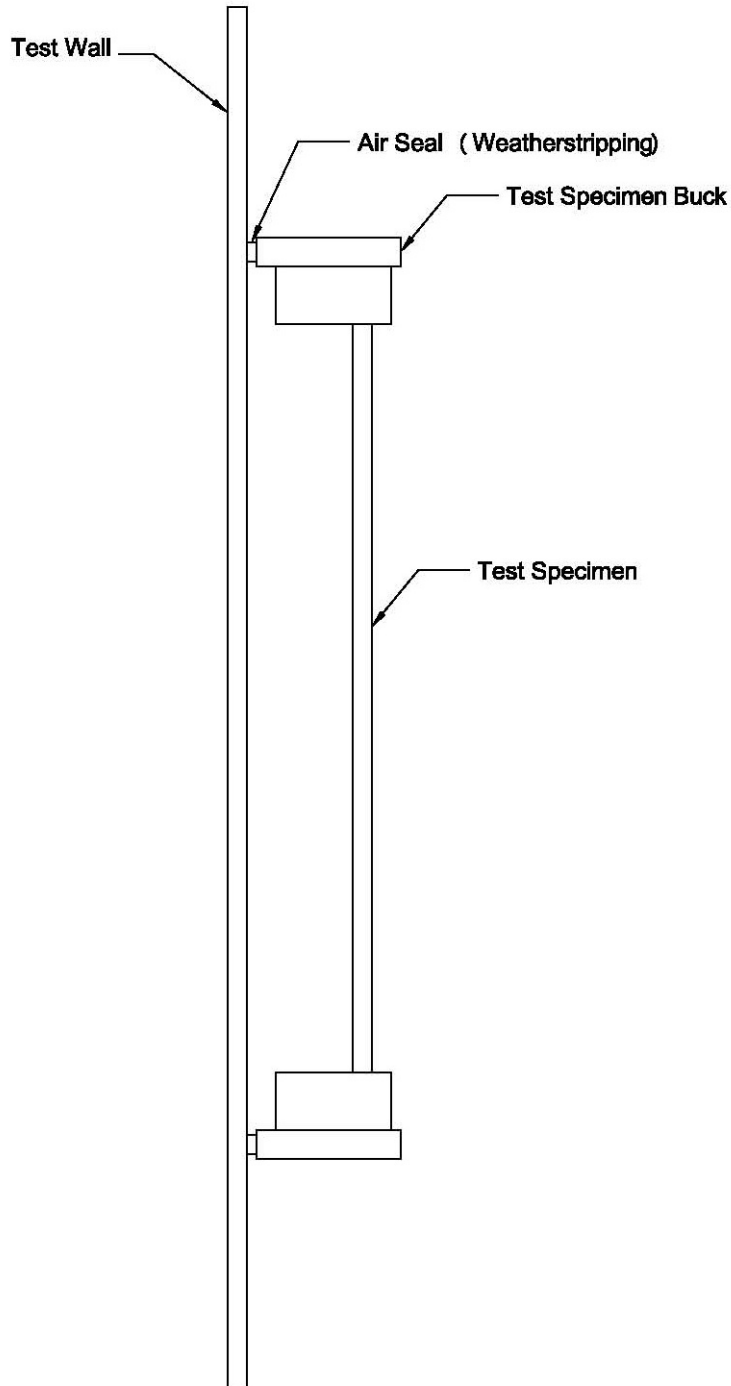



Appendix C

Drawing(s)

Note: Complete drawings packet on file with Intertek-ATI

NOTE:
 FOR OTHER PROFILE, GLAZING BEAD,
 & GLASS OPTIONS, PLEASE SEE THE
 LINEAL PROFILE CHARTS FOR THIS
 SYSTEM.

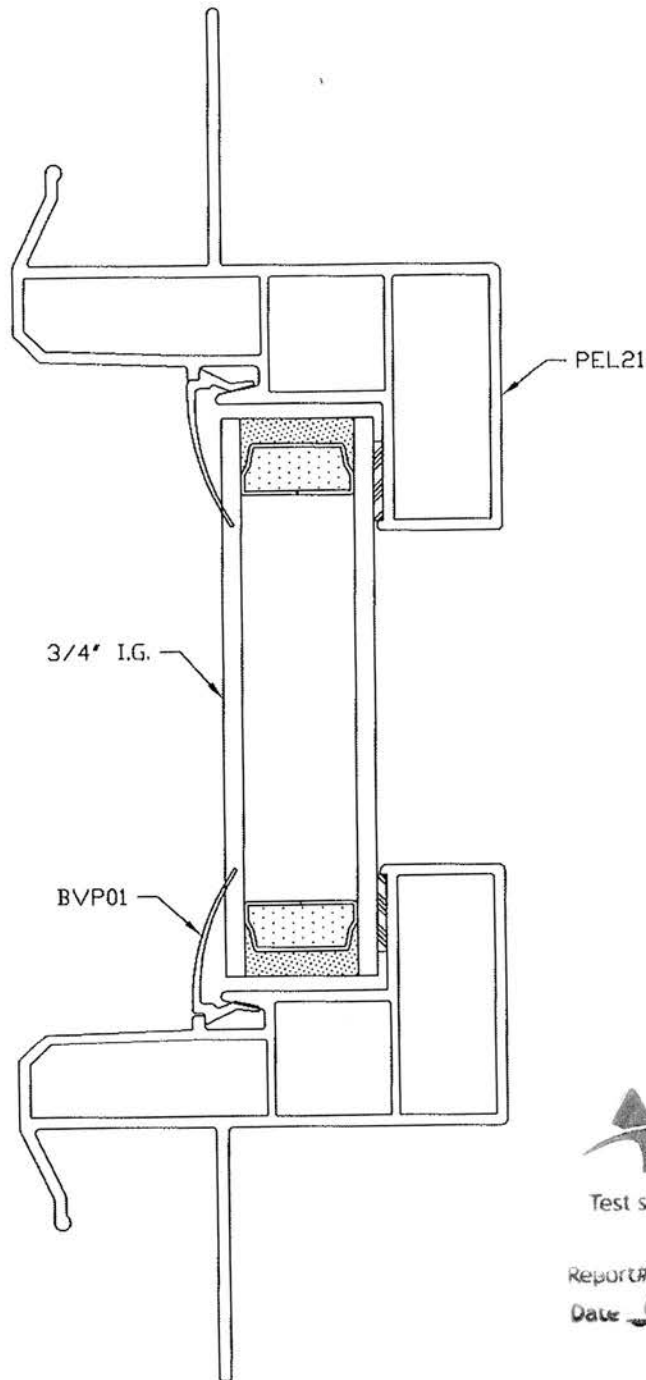

Test sample complies with these details
 Deviations are noted.

Report# E9101
 Date 6/29/15 Tech [Signature]

The information, design or data shown on this document or electronic media is the exclusive property of Veka Inc.. It is considered confidential and proprietary and is made available for limited use only. Its use or reproduction without the expressed written consent of Veka Inc. is prohibited.

		VEKA INC. 100 VEKA DRIVE FOMBELL, PA 16123	
		DRAWN: JMN	DATE: 9 JUNE 99
CHK'D:	DATE:	APPV'D:	
TITLE	PICTURE WINDOW PEL21W TYPICAL ASSEMBLY		DWG. # PEL21W