

	Document Title: Structural Performance Certification Authorization Report	Doc No: FRM B1-02		
		Rev No: 7	Page: 1	Of: 1
Required By: PRO B1-03				

CAR & Product ID Number: 757 - 115.0
Issue Date: 8/20/2015
Revision Date: 8/20/2015
Expiration Date: 6/24/2019
Company Code: 757

This Certification Authorization Report (CAR) is issued by Keystone Certifications, Inc. (KCI) after full validation review, and is based on a standardized evaluation of the product conducted by an independent accredited laboratory in accordance with the specified referenced standard. Actual fenestration product performance may vary based on many factors, including installation, condition of the wall/roof substrate and the age of the product and installation components.

This report indicates the product is eligible for the application of Keystone Certification Program certification labels. Licensee stipulates in affixing certification labels to products, that those products are representative of the specimen evaluated and documented for certification authorization. Only products bearing such a certification label shall be considered certified. The information in this report can be verified at www.keystonecerts.com.

Licensee Information: Pocahontas Aluminum Company, Inc. 2001 Industrial Drive PO Box 756 Pocahontas AR 72455	Product Information: Model: SHL21WW PVC Single Hung Operator Type: H Config: EM/IM, GS-1/8" Ann IG Max Width: 48 Max Height: 72
--	---

Referenced Standard: AAMA/WDMA/CSA 101/I.S.2/A440-08/11	Product Rating: Class R-PG20 1219x1829 (48x72)-H Neg DP=25
---	--

Qualifying Test Information:	
Test Report No:	ATI-E9099.02-501-47
Test Report Expiration:	6/24/2019

Authorized Signature:

Keystone Certifications, Inc.
564 Old York Road, Suite 5
Etters, Pennsylvania 17319
Phone: 717-932-8500
Fax: 717-932-8501

	Document Title:	Doc No:	FRM B1-02	
	Structural Performance Certification Authorization Report	Rev No: 7	Page: 1	Of: 1
Required By: PRO B1-03				

CAR & Product ID Number: 757 - 116.0
 Issue Date: 8/20/2015
 Revision Date: 8/20/2015
 Expiration Date: 6/24/2019
 Company Code: 757

This Certification Authorization Report (CAR) is issued by Keystone Certifications, Inc. (KCI) after full validation review, and is based on a standardized evaluation of the product conducted by an independent accredited laboratory in accordance with the specified referenced standard. Actual fenestration product performance may vary based on many factors, including installation, condition of the wall/roof substrate and the age of the product and installation components.

This report indicates the product is eligible for the application of Keystone Certification Program certification labels. Licensee stipulates in affixing certification labels to products, that those products are representative of the specimen evaluated and documented for certification authorization. Only products bearing such a certification label shall be considered certified. The information in this report can be verified at www.keystonecerts.com.

Licensee Information:	Product Information:
Pocahontas Aluminum Company, Inc. 2001 Industrial Drive PO Box 756 Pocahontas AR 72455	Model: SHL21WW PVC Single Hung Operator Type: H Config: EM/IM Max Width: 48 Max Height: 72

Referenced Standard:	Product Rating:
AAMA/WDMA/CSA 101/I.S.2/A440-08/11	Class R-PG20 914x1372* (36x54*)-H Neg DP=45

Qualifying Test Information:	
Test Report No:	ATI-E9099.02-501-47
Test Report Expiration:	6/24/2019

Authorized Signature:

Keystone Certifications, Inc.
 564 Old York Road, Suite 5
 Etners, Pennsylvania 17319
 Phone: 717-932-8500
 Fax: 717-932-8501



TEST REPORT

Report No.: E9099.02-501-47

Rendered to:

POCAHONTAS ALUMINUM COMPANY, INC.
Pocahontas, Arizona

PRODUCT TYPE: PVC Single Hung Window
SERIES/MODEL: SHL21WW

SPECIFICATION(S): AAMA/WDMA/CSA 101/I.S.2/A440-11, *NAFS 2011 - North American Fenestration Standard/Specification for Windows, Doors, and Skylights*

AAMA/WDMA/CSA 101/I.S.2/A440-08, *NAFS - North American Fenestration Standard/Specification for Windows, Doors, and Skylights*

Title	Summary of Results	
	Test Specimen #1	Test Specimen #2
AAMA/WDMA/CSA 101/I.S.2/A440-08 and -11	Class R-PG20 1219 x 1829 (48 x 72) - H	Class R-PG20 914 x 1372* (36 x 54*) - H
Design Pressure	±1200 Pa (±25.06 psf)	±2160 Pa (±45.11 psf)
Air Infiltration	1.5 L/s/m ² (0.30 cfm/ft ²)	1.4 L/s/m ² (0.27 cfm/ft ²)
Canadian Air Infiltration/Exfiltration Level	A2	A2
Water Penetration Resistance Test Pressure	150 Pa (3.13 psf)	See Test Specimen #1

Test Completion Date: 06/24/15

Reference must be made to Report No. E9099.02-501-47, dated 07/31/15 for complete test specimen description and detailed test results.



1.0 Report Issued To: Pocahontas Aluminum Co., Inc.
2001 Industrial Drive
Pocahontas, Arizona 72455

2.0 Test Laboratory: Architectural Testing, Inc., a subsidiary of Intertek (Intertek-ATI)
1140 Lincoln Avenue
Springdale, Pennsylvania 15144
724-275-7100

3.0 Project Summary:

3.1 Product Type: PVC Single Hung Window

3.2 Series/Model: SHL21WW

3.3 Compliance Statement: Results obtained are tested values and were secured by using the designated test method(s). The specimens tested successfully met the performance requirements for the following ratings:

Test Specimen(s)	Title	Summary of Results
1	101/I.S.2/A440-08 and -11	Class R-PG20 1219 x 1829 (48 x 72) - H
2	101/I.S.2/A440-08 and -11	Class R-PG20 914 x 1372* (36 x 54*) - H

General Note: An asterisk (*) next to the size designation indicates that the size tested for optional performance was smaller than the Gateway test size for the product type and class.

3.4 Test Dates: 06/22/15 - 06/24/15

3.5 Test Record Retention End Date: All test records for this report will be retained until June 24, 2019.

3.6 Test Location: Veka Inc. test facility in Fombell, Pennsylvania. Calibration of test equipment was performed by Intertek-ATI in accordance with AAMA 205-01 "In-Plant Testing Guidelines for Manufacturers and Independent Laboratories".

3.7 Test Specimen Source: The test specimens were provided by the client. Representative samples of the test specimen(s) will be retained by Intertek-ATI for a minimum of four years from the test completion date.

3.8 Drawing Reference: The test specimen drawings have been reviewed by Intertek-ATI and are representative of the test specimen(s) reported herein. Test specimen construction was verified by Intertek-ATI per the drawings located in Appendix C. Any deviations are documented herein or on the drawings.

3.9 List of Official Observers:

<u>Name</u>	<u>Company</u>
Doug Merry	Veka Inc.
Cornell Charles	Veka Inc.
Joseph Allison	Intertek-ATI

4.0 Test Specification(s):

AAMA/WDMA/CSA 101/I.S.2/A440-11, *NAFS 2011 - North American Fenestration Standard/Specification for Windows, Doors, and Skylights*

AAMA/WDMA/CSA 101/I.S.2/A440-08, *NAFS - North American Fenestration Standard/Specification for Windows, Doors, and Skylights*

5.0 Test Specimen Description:

5.1 Product Sizes:

Test Specimen #1:

Overall Area: 2.2 m ² (24.0 ft ²)	Width		Height	
	millimeters	inches	millimeters	inches
Overall size	1219	48	1829	72
Sash size	1168	46	924	36-3/8
Screen size	1181	46-1/2	895	35-1/4

Test Specimen #2:

Overall Area: 2.1 m ² (22.2 ft ²)	Width		Height	
	millimeters	inches	millimeters	inches
Overall size	914	36	1372	54
Sash size	864	34	695	27-3/8
Screen size	876	34-1/2	667	26-1/4

The following descriptions apply to all specimens.

5.2 Frame Construction:

Frame Member	Material	Description
Head, sill, jambs, fixed rail	PVC	Extruded

	Joinery Type	Detail
All corners	Mitered	Thermally welded
Fixed rail	Square-cut and coped	Fastened with four #8 x 2" truss head screws, two at each end, and sealed with a silicone sealant

5.0 Test Specimen Description: (Continued)

5.3 Sash Construction:

Sash Member	Material	Description
All rails and stiles	PVC	Extruded

	Joinery Type	Detail
All corners	Mitered	Thermally welded

5.4 Weatherstripping:

Description	Quantity	Location
0.187" backed x 0.250" high center fin pile	1 Row	Top rail, bottom rail, stiles

5.5 Glazing: *No conclusions of any kind regarding the adequacy or inadequacy of the glass in any glazed test specimen(s) can be made.*

Test Specimen #1:

Glass Type	Spacer Type	Interior Lite	Exterior Lite	Glazing Method
5/8" IG	Rectangular-shaped steel, single sealed	1/8" annealed	1/8" annealed	The glass was set from the exterior against a silicone sealant and secured with rigid PVC glazing beads

Test Specimen #2:

Glass Type	Spacer Type	Interior Lite	Exterior Lite	Glazing Method
5/8" IG	Rectangular-shaped steel, single sealed	3/32" annealed	3/32" annealed	The glass was set from the exterior against a silicone sealant and secured with rigid PVC glazing beads

Location	Quantity	Daylight Opening		Glass Bite
		millimeters	inches	
Specimen #1 sash	1	1089 x 845	42-7/8 x 33-1/4	5/8"
Specimen #1 frame	1	1149 x 845	45-1/4 x 33-1/4	5/8"
Specimen #1 sash	1	784 x 616	30-7/8 x 24-1/4	5/8"
Specimen #1 frame	1	845 x 616	33-1/4 x 24-1/4	5/8"

5.0 Test Specimen Description: (Continued)

5.6 Drainage:

Drainage Method	Size	Quantity	Location
Weepslot	9/16" wide by 5/32" high	2	Exterior sill face, one 2" in from each end.
Weepslot	9/16" wide by 5/32" deep	2	Interior sill track, one at each end.

5.7 Hardware:

Description	Quantity	Location
Metal cam lock	2	Lock rail, one 10" in from each end with mating metal keepers on the fixed meeting rail.
Metal surface mount tilt latch	2	Top rail, one at each end
Metal tilt pin	2	Bottom rail, one at each end
Block and tackle balance system	2	One per jamb

5.8 Reinforcement:

Drawing Number	Location	Material
S-3832	Fixed rail, lock rail	Extruded aluminum

5.9 Screen Construction:

Frame Material	Corner Construction	Mesh Type	Mesh Attachment Method
Roll-formed aluminum	Square-cut and secured with snap-in plastic corner keys	Fiber	Flexible vinyl spline

6.0 Installation:

The specimen was installed into a Spruce-Pine-Fir wood buck. The rough opening allowed for a 1/8" shim space. The nail fin perimeter of the window was sealed with a silicone sealant.

Location	Anchor Description	Anchor Location
Integral nail fin	#8 x 2" long truss head screws	Nominally spaced at 9" on center, and beginning 2" in from each corner, with an additional three screw cluster at each end of the fixed meeting rail

7.0 Test Results: The temperature during testing was 21°C (70°F). The results are tabulated as follows:

Test Specimen #1:

Title of Test	Results	Allowed	Note
Operating Force, per ASTM E 2068	Initiate motion: 155 N (35 lbf) Maintain motion: 155 N (35 lbf) Latches: 44 N (10 lbf) Locks: 22 N (5 lbf)	Report Only 155 N (35 lbf) max. 100 N (22.5 lbf) max. 100 N (22.5 lbf) max.	
Air Leakage, Infiltration per ASTM E 283 at 75 Pa (1.57 psf)	1.5 L/s/m ² (0.30 cfm/ft ²)	1.5 L/s/m ² (0.3 cfm/ft ²) max.	1
Air Leakage, Exfiltration per ASTM E 283 at 75 Pa (1.57 psf)	0.7 L/s/m ² (0.14 cfm/ft ²)	1.5 L/s/m ² (0.3 cfm/ft ²) max.	1
Canadian Air Infiltration/Exfiltration Level	A2	N/A	
Water Penetration, per ASTM E 547	N/A	N/A	3
Uniform Load Deflection, per ASTM E 330	N/A	N/A	3
Uniform Load Structural, per ASTM E 330	N/A	N/A	3
Forced Entry Resistance, per ASTM F 588, Type: A - Grade: 10	Pass	No entry	
Thermoplastic Corner Weld	Pass	Meets as stated	
Deglazing, per ASTM E 987 Operating direction, 320 N (72 lbf) Remaining direction, 230 N (52 lbf)	Pass Pass	Meets as stated Meets as stated	

7.0 Test Results: (Continued)

Test Specimen #1: (Continued)

Title of Test	Results	Allowed	Note
Optional Performance			
Water Penetration, per ASTM E 547 at 150 Pa (3.13 psf)	Pass	No leakage	2
Uniform Load Deflection, per ASTM E 330 Deflections taken at the fixed meeting rail +1200 Pa (+25.06 psf) -1200 Pa (-25.06 psf)	22.3 mm (0.88") 19.8 mm (0.78")	Report Only	4, 5, 6
Uniform Load Structural, per ASTM E 330 Permanent sets taken at the fixed meeting rail +1800 Pa (+37.59 psf) -1800 Pa (-37.59 psf)	1.5 mm (0.06") 1.0 mm (0.04")	4.8 mm (0.19") max. 4.8 mm (0.19") max.	5,6

Test Specimen #2:

Title of Test	Results	Allowed	Note
Optional Performance			
Air Leakage, Infiltration per ASTM E 283 at 75 Pa (1.57 psf)	1.4 L/s/m ² (0.27 cfm/ft ²)	1.5 L/s/m ² (0.3 cfm/ft ²) max.	1
Air Leakage, Exfiltration per ASTM E 283 at 75 Pa (1.57 psf)	1.1 L/s/m ² (0.22 cfm/ft ²)	1.5 L/s/m ² (0.3 cfm/ft ²) max.	1
Canadian Air Infiltration/Exfiltration Level	A2	N/A	
Uniform Load Deflection, per ASTM E 330 taken at the fixed meeting stile +2160 Pa (+45.11 psf) -2160 Pa (-45.11 psf)	12.8 mm (0.50") 11.3 mm (0.44")	Report Only	4, 5, 6
Uniform Load Structural, per ASTM E 330 taken at the fixed meeting stile +3240 Pa (+67.67 psf) -3240 Pa (-67.67 psf)	1.0 mm (0.04") 0.8 mm (0.03")	3.6 mm (0.14") max. 3.6 mm (0.14") max.	5, 6

7.0 Test Results: (Continued)

Note 1: The tested specimen meets (or exceeds) the performance levels specified in AAMA/WDMA/CSA 101/I.S.2/A440 for air leakage resistance.

Note 2: With and without insect screen.

Note 3: The client opted to start at a pressure higher than the minimum required. Test results are reported under Optional Performance.

Note 4: The deflections reported are not limited by AAMA/WDMA/CSA 101/I.S.2/A440 for this product designation. The deflection data is recorded in this report for special code compliance and information only.

Note 5: Loads were held for 10 seconds.

Note 6: Tape and film were used to seal against air leakage during structural testing. In our opinion, the tape and film did not influence the results of the test.



Intertek-ATI will service this report for the entire test record retention period. Test records such as detailed drawings, datasheets, representative samples of test specimens, or other pertinent project documentation, will be retained by Intertek-ATI for the entire test record retention period.

This report does not constitute certification of this product nor an opinion or endorsement by this laboratory. It is the exclusive property of the client so named herein and relates only to the specimen(s) tested. This report may not be reproduced, except in full, without the written approval of Intertek-ATI.

For INTERTEK-ATI

Joseph E. Allison
Senior Technician

Lynn George
Director – Regional Operations

JEA:sld

Attachments (pages): This report is complete only when all attachments listed are included.

Appendix-A: Alteration Addendum (1)

Appendix-B: Location of Air Seal (1)

Appendix- C: Drawing(s) (2) Complete drawings packet on file with Intertek-ATI



Appendix A

Alteration Addendum

Note: No alterations were required.

Appendix B

Location of Air Seal: The air seal between the test specimen and the test wall is detailed below. The seal is made of foam weatherstripping and is attached to the edge of the test specimen buck. The test specimen buck is placed against the test wall and clamped in place, compressing the weatherstripping and creating a seal.

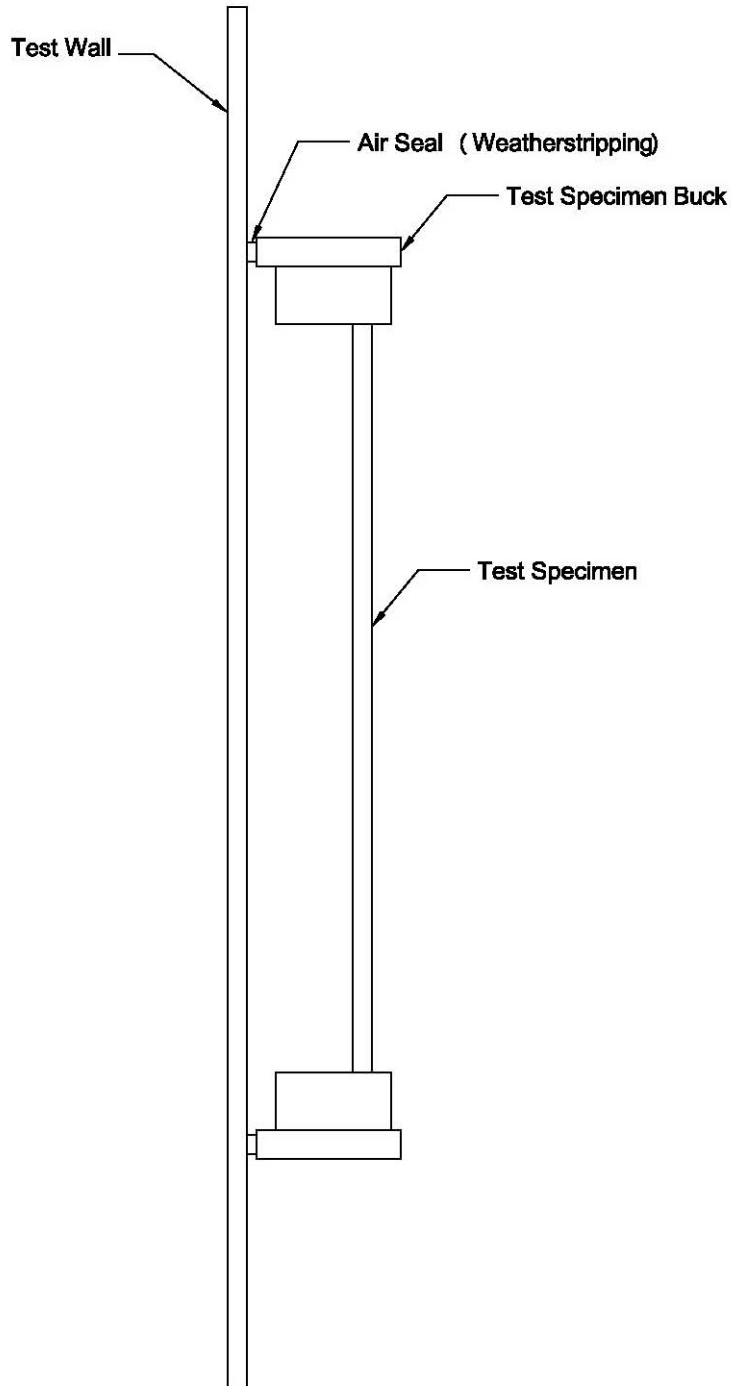



Appendix C

Drawing(s)

Note: Complete drawings packet on file with Intertek-ATI

NOTE:
 FOR OTHER PROFILE, GLAZING BEAD,
 & GLASS OPTIONS, PLEASE SEE THE
 LINEAL PROFILE CHARTS FOR THIS
 SYSTEM.



Test sample complies with these details.
 Deviations are noted.

Report# 129099
 Date 6/30/15 Tech JEA

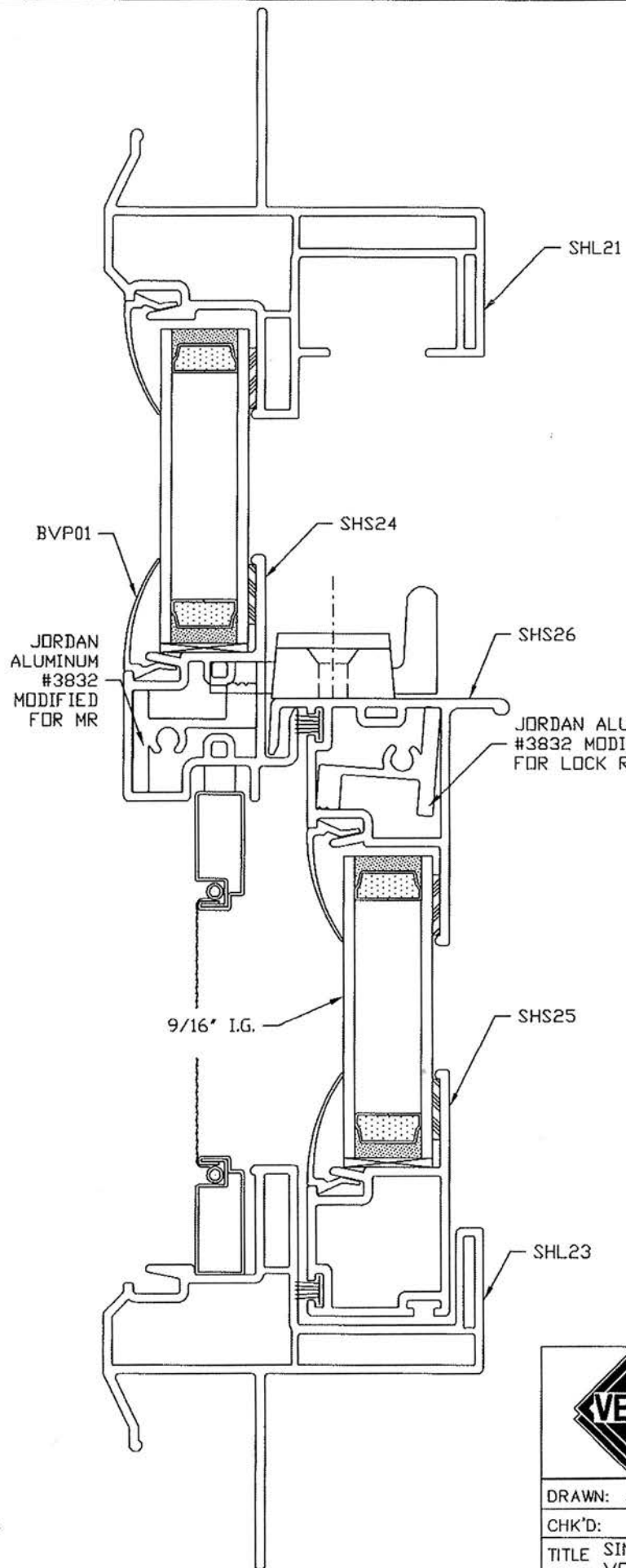

POCAHONTAS

The information, design or data shown on this document or electronic media is the exclusive property of Veka Inc.. It is considered confidential and proprietary and is made available for limited use only. Its use or reproduction without the expressed written consent of Veka Inc. is prohibited.



VEKA INC.
 100 VEKA DRIVE
 FOMBELL, PA 16123

DRAWN: JMN	DATE: 14 AUG 00	SCALE: FULL
CHK'D:	DATE:	APP'V'D:
TITLE SINGLE HUNG SHL21WW VERTICAL ASSEMBLY		DWG. #SHL21WW-V

NOTE:
 FOR OTHER PROFILE, GLAZING BEAD,
 & GLASS OPTIONS, PLEASE SEE THE
 LINEAL PROFILE CHARTS FOR THIS
 SYSTEM.

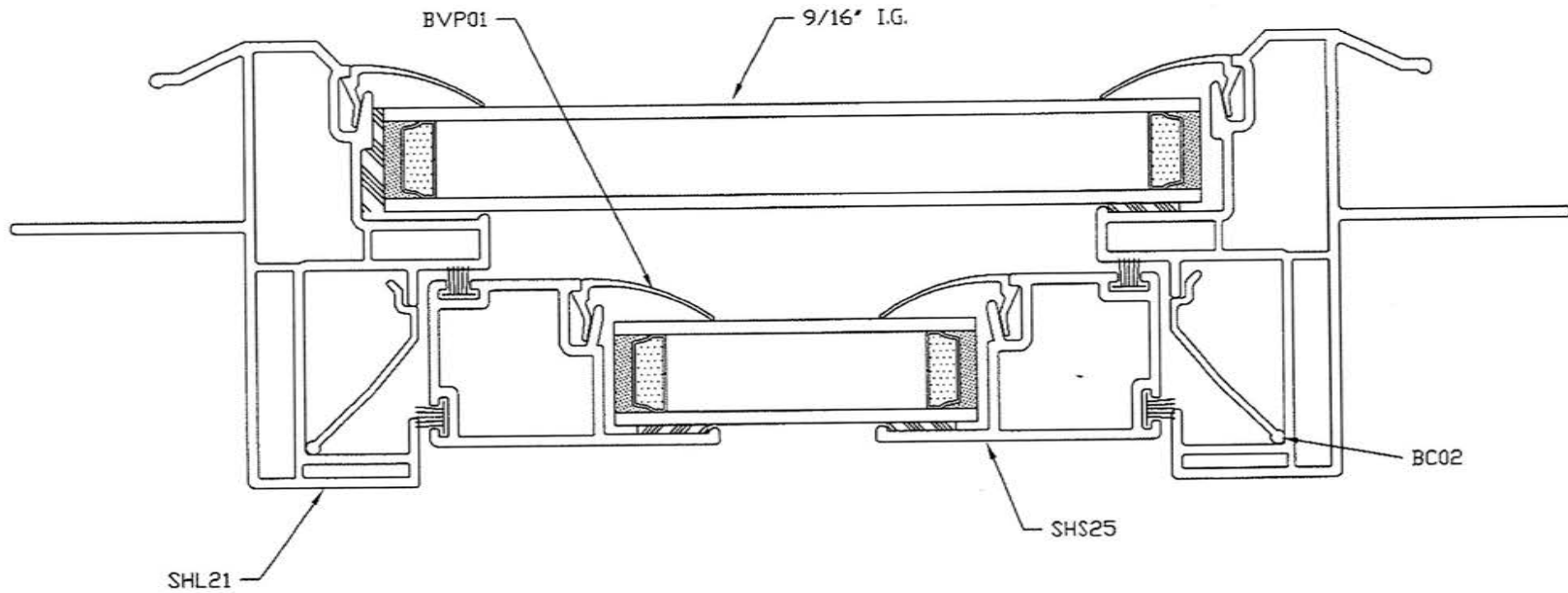

Test sample complies with these details.
 Deviations are noted.

Report# E9099
 Date 6/30/15 Tech JES

The information, design or data shown on this document or electronic media is the exclusive property of Veka Inc. It is considered confidential and proprietary and is made available for limited use only. Its use or reproduction without the expressed written consent of Veka Inc. is prohibited.



VEKA INC.
 100 VEKA DRIVE
 FOMBELL, PA 16123

DRAWN: JMN	DATE: 14 AUG 00	SCALE: FULL
CHK'D:	DATE:	APPVD:
TITLE: SINGLE HUNG SHL21WW HORIZONTAL ASSEMBLY		DWG. # SHL21WW-H